

REGENCY[®]

CEILING FANS

Style that revolves around you.

• CEILING FAN OWNER'S MANUAL •



Total fan weight
***53 lbs.**

• WEXFORD •

11/05

WARNING: Read and follow these instructions carefully and be mindful of all warnings shown throughout.

IMPORTANT SAFEGUARDS:

1. **To ensure the success of the installation, be sure to read the instructions and review the diagrams thoroughly before beginning.**
2. **To avoid possible electric shock, be sure electricity is turned off at the main power box before wiring.** All electrical connections must be made in accordance with local codes, ordinances and/or the National Electric Code. If you are unfamiliar with the methods of installing electrical wiring and products, secure the services of a qualified and licensed electrician as well as someone who can check the strength of the supportive ceiling members and make the proper installation(s) and connections.
3. Make sure that your installation site will not allow rotating fan blades to come in contact with any object. Blades should be at least 7 feet from floor.
4. When mounting on a ceiling outlet box, an approved box UL listed as “**suitable for fan support**” is required. The box and its supporting members must be able to support the moving weight of the fan’s listed weight. The box must not be able to twist or work loose. Installation on a concrete ceiling should be performed by qualified personnel.
5. Blades should be attached after motor housing is hung and in place. Fan motor housing should be kept in the carton until ready to be installed to protect its finish. If you are installing more than one ceiling fan, make sure that you **do not mix fan blade sets**, as each blade is part of a weighted set.
6. After making electrical connections, spliced conductors should be turned upward and pushed carefully up into outlet box. The wires should be spread apart with the common conductor and the grounding conductor on one side of the outlet box, and the “HOT” wires on the other side.
7. Electrical diagrams are for reference only. Light kits that are not packed with the fan must be UL listed and should be installed per the light kit’s installation instructions.
8. After fan is completely installed, check to make sure that all connections are secure to prevent fan from falling and/or causing damage or injury.
9. The fan can be made to work immediately after installation - the bearings are adequately charged with grease so that, under normal conditions, further lubrication should not be necessary for the life of the fan.
10. The fan should be turned off and allowed to stop rotating before reversing fan direction.
11. **Please note that the total wattage of the fan, the uplights and an optional downlight cannot exceed 300 watts.**

*Thank you for choosing a Regency Ceiling Fan. You have chosen the best!
Your new ceiling fan has been designed to provide many years of service and enjoyment.*

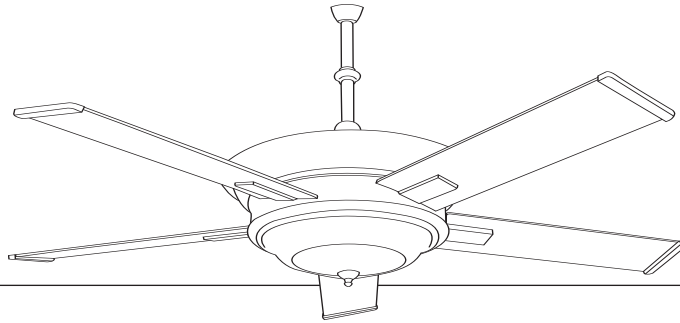

Warnings:

- **Disconnect power by removing fuse or turning off circuit breaker before installing the fan and/or optional lighting.**
- Support directly from building structure.
- To reduce the risk of fire, electric shock, or personal injury, mount to outlet box marked “**acceptable for fan support**” and use mounting screws provided with the outlet box. Most outlet boxes commonly used for the support of lighting fixtures are not acceptable for fan support and may need to be replaced. Consult a qualified electrician if in doubt.
- To reduce the risk of fire, electrical shock, or personal injury, only use this fan with an appropriate speed control device designed for use with ceiling fans if you choose a wall control. **DO NOT USE INCANDESCENT LIGHT DIMMER. Do not use this fan with any transformer type fan speed control device.**
- To reduce the risk of personal injury, do not bend the blade arms when installing them, balancing the blades or cleaning the fan. Do not insert any object(s) between rotating fan blades.

NOTE: The important precautions, safeguards and instructions appearing in this manual are not meant to cover all possible conditions and situations that may occur. It must be understood that common sense, caution and carefulness are factors which cannot be built into this product. These factors must be supplied by the person(s) installing, caring for, and operating the unit.

TOOLS AND MATERIALS REQUIRED

- Phillips screwdriver
- Blade screwdriver
- Wrench or pliers
- Wire cutter
- Stepladder
- Wiring supplies as required by electrical code

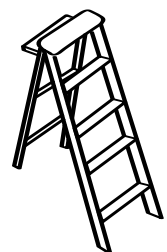
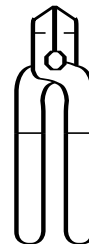
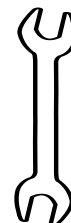

Unpack your fan and check the contents. Do not discard the carton. If warranty replacement or repair is ever necessary, the fan should be returned in original packaging. Remove all parts and hardware. Do not lay motor housing on its side – the decorative housing may become bent or damaged. Use styrofoam packing to support the fan body during assembly.

Examine all parts. You should have the following:

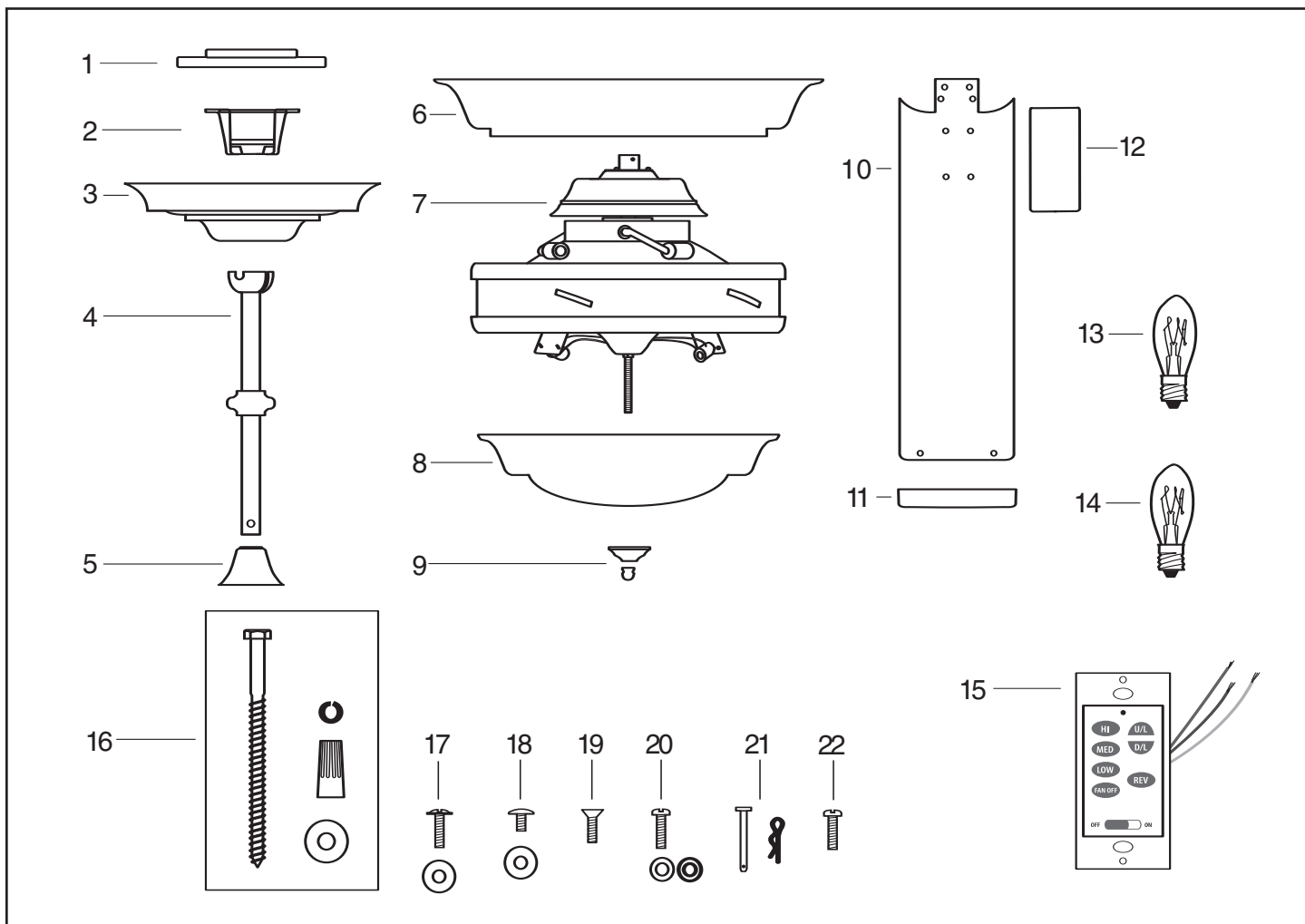

- | | |
|----------------------------------|--|
| 1. Mounting bracket | 12. Blade base decoration (base-5) |
| 2. Hanging bracket | 13. Candelabra bulbs (4) 40w uplighting |
| 3. Canopy | 14. Candelabra bulbs (4) 40w downlight |
| 4. Downrod, ball, decoration | 15. In-wall remote control transmitter (2WWCD) |
| 5. Collar cover | 16. Bracket hardware (wood screws, washers, wire nuts) |
| 6. Top glass | 17. Blade to motor screws w/fiber washers (long-20) |
| 7. Fan body (motor) | 18. Blade base decoration screws w/washers (20) |
| 8. Bottom glass | 19. Blade tip decoration screws (10) |
| 9. Bottom cap, finial | 20. Top glass screws w/metal and rubber washers (4) |
| 10. Blade set (5) | 21. Downrod pin, cotter pin |
| 11. Blade tip decoration (tip-5) | 22. Canopy screws (2) |

PREPARATION



Parts identification on assembled fan

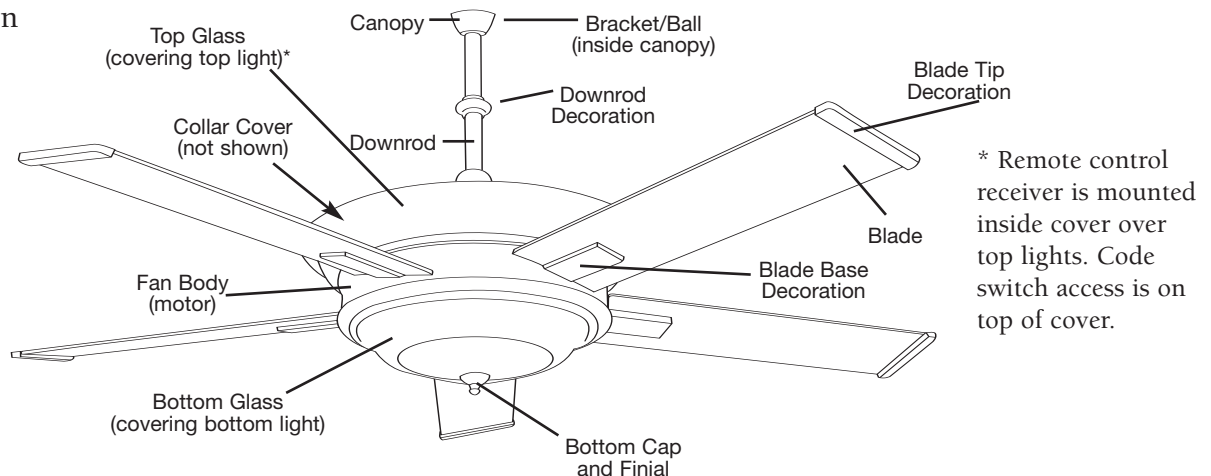

PRE-INSTALLATION TIPS

Caution: To avoid possible electrical shock, make sure electricity is turned off at the main power box before wiring. All wiring must be in accordance with National Electrical Code, local codes and ordinances. The ceiling fan must be grounded as a precaution against possible electrical shock.

Installation of this fan should be done by a professional or qualified person. Fan weight is of concern because most installation will not support the weight of this fan. It is suggested that an electrical box assembly capable of supporting a weight of 70 lbs or greater be used in this installation. When selecting a box to be used, you should take into account all of the issues that could affect your fan's operation.

Noise: Depending on the type of electrical box picked, it could affect how noise transfers through the home by way of ceiling joists. A stand-alone type box that mounts directly to the joist will transfer noise directly from the motor to the joist and into the house. In some cases this is the only option available. Another option is a suspended type box that spans between 2 joists. This can result in less noise moving from fan to joist.

Fan Movement: Because of the weight of larger fans, the electrical box installation can cause the fan to move because of the looseness in the installation of the box. Select a box that is sturdy and has no movement once it is installed in the ceiling to the joist. In this case, a stand-alone box works the best, but suspended types are available that have good rigid quality.

Ceiling Bow: Again, when selecting an electrical box installation, you should take into account that bow can become an issue over time. This issue is more of a problem on joists that are spaced on a 24" center. Again, a stand-alone type box works best, but is not a guarantee against bow. It is suggested on 24" spans that horizontal reinforcement be made that would tie together opposite sides of the joist that hold the fan. This will stop sag or bow from becoming a problem over time. This could also be used if using a suspended type box and will work just as well as a stand-alone box.

Joist Size: Before you install your fan, determine the type of joist size used in your home. If your joist size is less than a 2 x 6, you should take extra caution in how you install your fan. Refer to a qualified installer about your installation.

Consult a professional before you install your fan about all installation issues if uncertain.

Caution: To avoid possible electrical shock, make sure electricity is turned off at the main power box before wiring. All wiring must be in accordance with National Electrical Codes and the ceiling fan must be grounded as a precaution against possible electrical shock.

Pre-Existing Installation: (box rated for 70 lbs or greater)

With the electrical box located and weight load confirmed, check that the location agrees with the requirements in the minimum clearance safeguards section of this guide. If you are not sure of the weight load rating with your box, then use the mounting bracket assembly that comes with your fan to strengthen your existing box installation.

Note: Box must be listed for ceiling fan use.

(Option) Mounting Bracket Installation: If using the mounting bracket that comes with your fan, remove from packing and check that all parts are present.

Depending on the electrical box that you have in your installation, check and see which holes will work for your installation. Line up holes in the bracket with holes in the top of your box. The existing box installation will determine if you will be using the inner most mounting holes or the outer most mounting holes in the mounting bracket.

Note: In some applications you may need to drill out the electrical box to use the mounting bracket. Check the box for obstructions before drilling.

Now that you know what holes will be used, check clearance issues. The top of the box will need to have a stud passing over the top of the box for lag screws to thread into. If you are not sure of this part, refer to a qualified person to check or install this portion of the installation.

With a stud located correctly above the box, drill out mounting holes with proper drill hole size. If you are not sure, refer to a qualified person on this issue. With the holes drilled, assemble mounting bracket with insulator on mounting screws.

Install mounting bracket to electrical box with wires feeding through the center of the bracket and tighten lag screws.

Note: Trim dry wall if needed for fit.

Install the hanging bracket to the mounting bracket using washers and self locking nuts supplied with the mounting bracket assembly. If using a pre-installed electrical box that is rated for 70 lbs or greater, use hardware from the box to install the hanging bracket onto the electrical box per instruction sheet that manufacturer supplied with the box.

Note: If using in a new installation, make sure that a switch is installed between the fan and power in accordance with National Electrical Code.

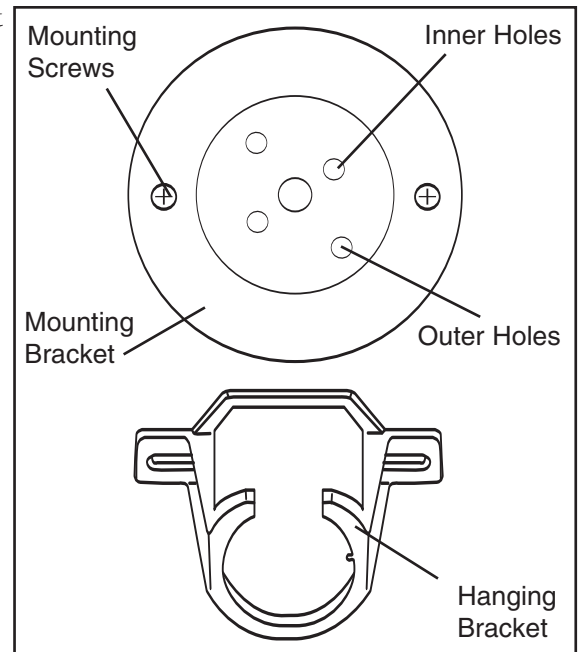

ATTACHING DOWNROD, CANOPY, COLLAR COVER AND DOWNROD DECORATION (FIG. 3):

1. Carefully support fan body (motor) in its styrofoam packing with the mounting collar (where the wires come out) facing upward. Be careful not to bend threaded pipe or crush light sockets on bottom side of fan body.
2. Remove downrod decoration by loosening both set screws.
3. Remove ball from downrod by loosening set screw in the side of the ball. Slide ball down and remove ball pin; remove ball.
4. Feed the wires from top of fan through end of downrod and thread downrod into mounting collar so the hole in the downrod lines up with the hole in the side of the mounting collar.
5. Insert downrod pin through holes in mounting collar and downrod; slip cotter pin through small hole in end of downrod pin to hold downrod pin in place.
6. Tighten security screws against downrod using a large flat blade screwdriver to ensure a tight fit against downrod. Then tighten lock nuts against mounting collar.

NOTE: Fan has 6 feet of hook-up wire in case you are using a long extension downrod. Wires can be cut so only 8 inches or so extend beyond the top of the downrod to make the electrical connections easier and safer.

7. Make sure rubber ring is snapped into top opening of collar cover. Feed wires through and slide collar cover down the downrod to top of fan.
8. Feed wires through downrod decoration and slide the decoration down to the midpoint of the downrod. Tighten set screw in the decoration to hold it securely in place on the downrod.
9. Feed wires through canopy and slide canopy over downrod to lay on top of downrod decoration. It will be attached to ceiling later.
10. Feed wires through ball and slide ball over downrod, past hole in the top end of downrod. Insert ball pin (removed in Step 3), slide ball up and tighten set screw to secure ball in place.

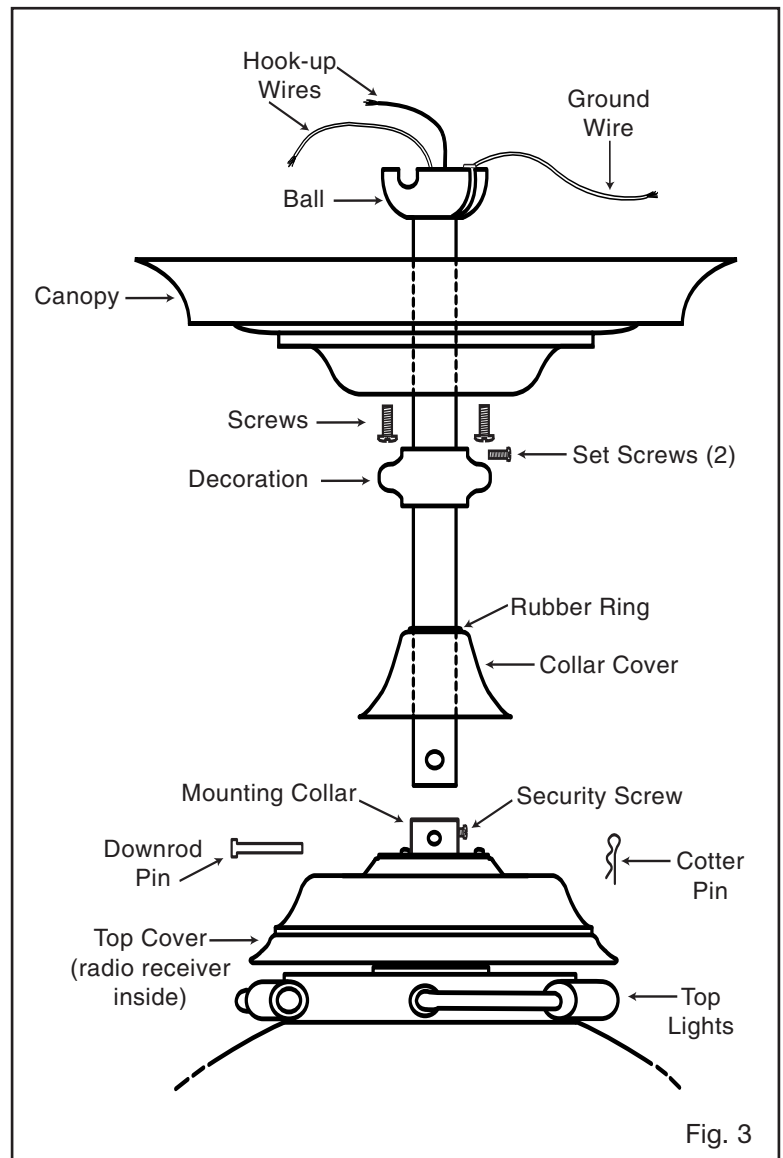

Fig. 3

INSTALLING TOP LIGHT AND GLASS



1. Carefully unpack top glass and lower over the downrod assembly into position on top of the fan body (Fig. 4).
2. Secure top glass using 4 screws, metal washers, and rubber washers provided. **DO NOT OVERTIGHTEN OR GLASS MAY BREAK!**
3. Install candelabra base (E12) bulbs (40w max per bulb) into top light sockets. **NOTE:** Some applications require only 15-25w bulbs to achieve desired lighting balance with bottom light. Experiment for best lighting effect.
- * 4. Note the position of 4 code switches on radio receiver just above top lights. The handheld remote control code switches must be set to the same positions (See page 10).

NOTE: Do not use factory settings, reset code switches.

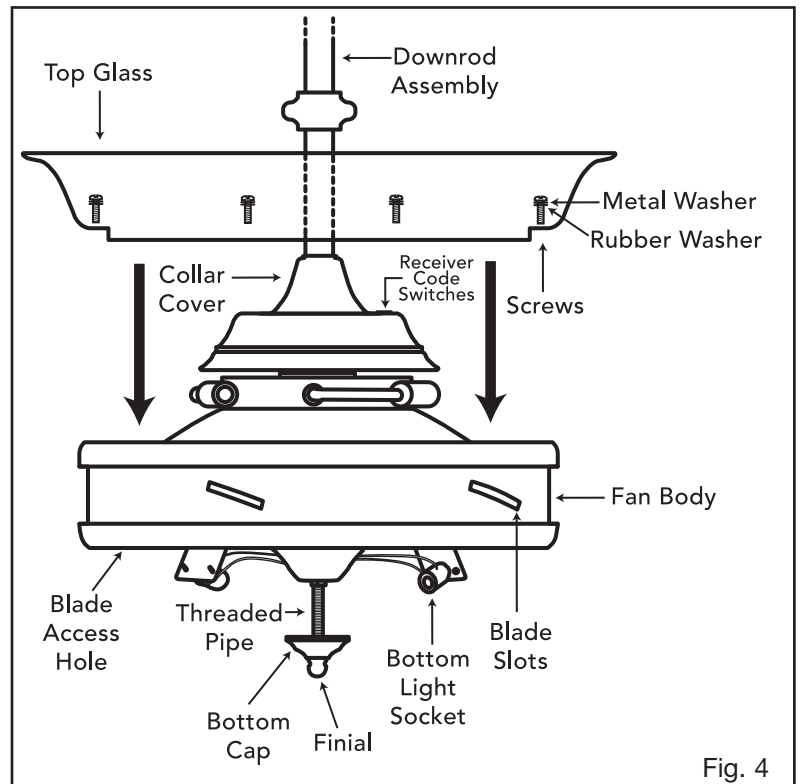

INSTALLING THE FAN

HANGING THE FAN

WARNING: To avoid damaging the blade arms and blades, do not install them onto fan until fan is fastened to ceiling.

1. Lift ball/downrod/fan into hanging bracket opening.
NOTE: The tab opposite hanging bracket opening should fit in slot on ball.
2. Make wire connections, (refer below to “Electrical Connections”).
3. Slide canopy up and fasten to hanging bracket with 2 screws provided.

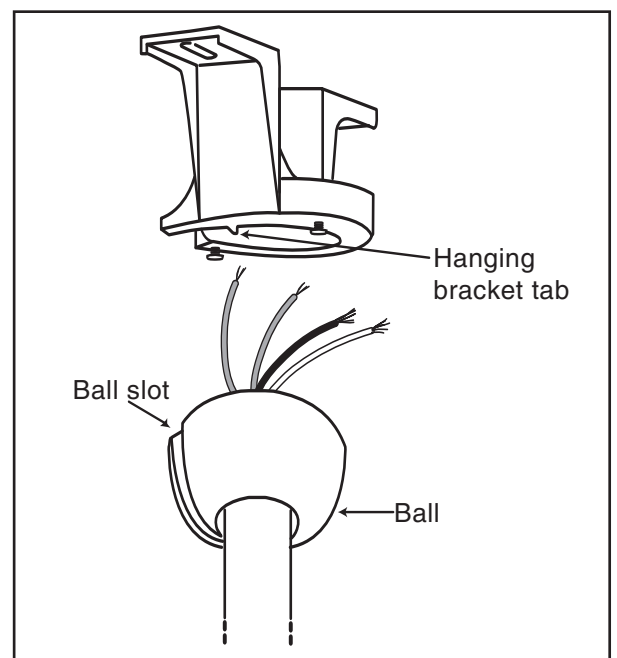

ELECTRICAL CONNECTIONS: (FIG. 6) ! Be sure electricity is turned off at the main power box before wiring.*

Three wires are connected to the fan.

Black - this is the “hot” power to run fan and light, also referred to as “AC line” or “supply”.

White - this is the “common” power to run fan and light, also referred to as “AC neutral”.

Green - ground wires.

1. Connect black house wire to black fan wire using wire nuts provided.
2. Connect white house wire to white fan wire using wire nuts provided.
3. Connect all green wires together and to house ground.

NOTE: If ON/OFF slide switch is turned off on wall controller, all fan functions will stop working.

* Restore power by replacing fuse or resetting circuit breaker **ONLY AFTER ALL INSTALLATION AND ELECTRICAL WORK IS COMPLETED AND DOUBLE-CHECKED.**

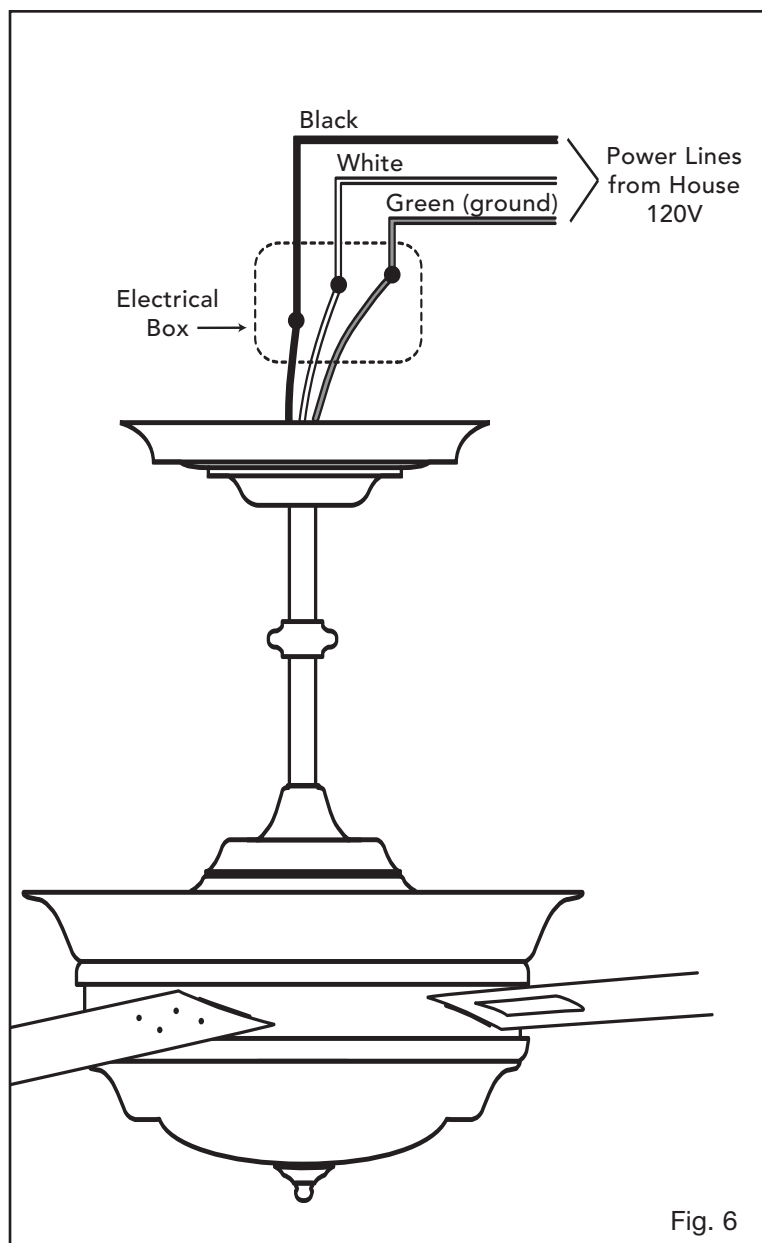

Fig. 6

ATTACHING BLADE DECORATIONS:

1. Attach blade base decorations to each blade using 4 screws and metal washers provided (Fig. 7). Tighten snugly, but do not over-tighten.
2. Attach blade tip decorations to each blade using 2 screws provided (Fig. 7). Tighten until screw head is flush with back surface of the blade.

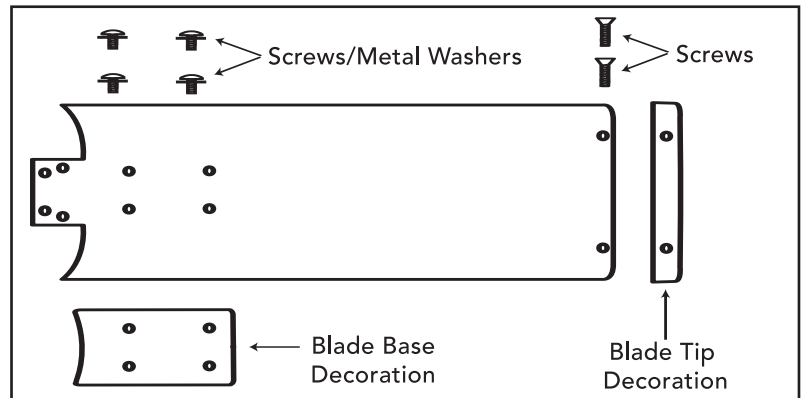

Fig. 7

ATTACHING THE BLADES:

1. Remove access panel on bottom of motor housing panel; panel has two screws holding panel on. Once removed blades can be installed in to motor. See Fig. 8
2. Insert blades through slots in side of fan motor, decoration side down, and align blade holes with holes in motor (Fig. 4).
3. Through the blade access hole (Fig. 4), start blade screws with fiber washers into each hole. **DO NOT TIGHTEN UNTIL ALL 4 SCREWS PER BLADE HAVE BEEN STARTED.** Repeat for remaining blades.
4. Tighten all 20 blade screws evenly and securely to ensure quiet, wobble-free operation of your fan.

NOTE: Cordless power screwdrivers are NOT recommended, as they tend to strip the heads of the screws and usually will not fully compress the spring washers on the motor screws. Use a large flat blade screwdriver for final tightening to fully compress the spring washers. This will help ensure proper alignment of the blades and noise-free, wobble-free running.

INSTALLING BOTTOM LIGHT AND GLASS (FIG. 8)

1. Install 4 mini candelabra base (E-12) bulbs (provided) into the 4 sockets of bottom light. These are incandescent bulbs (40w each).
2. Install bottom glass with bottom cap onto threaded pipe by screwing finial onto end of pipe. Make sure finial is secure, but only finger tight. **DO NOT** use wrench or pliers to overtighten or glass might break!

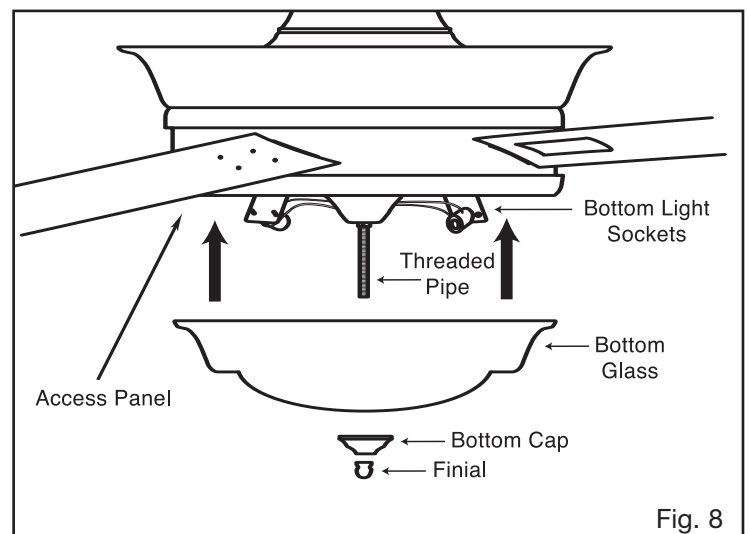

Fig. 8

GENERAL INFORMATION

Multiple code choices are included with your fan's remote control in case:

- you have more than one remote control fan and want them to respond only to their own remote control
- you have other radio controlled devices in your home that may interfere with the fan remote control (i.e. garage door opener)
- you experience radio interference on a chosen frequency (code setting)
- do not use factory settings

SET-UP AND OPERATING INSTRUCTIONS

Setting the code:

This unit has 16 different code combinations. To set the code, perform these steps:

1. Setting the code on the TRANSMITTER:
 - a. Remove battery cover.
 - b. Slide code switches to your choice of ON or OFF position. Use a small screwdriver or ball point pen to slide each switch firmly up or down (Fig. 9).
 - c. Install 9v battery (not included)
 - d. Replace battery cover on transmitter.
2. Setting the code on the RECEIVER:
 - a. Locate the code switches on top of fan body (Fig. 10).
 - b. Slide code switches to the SAME POSITIONS as set on your transmitter.

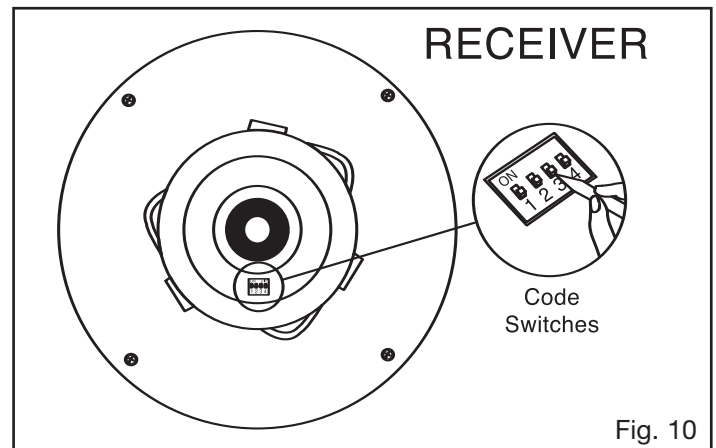
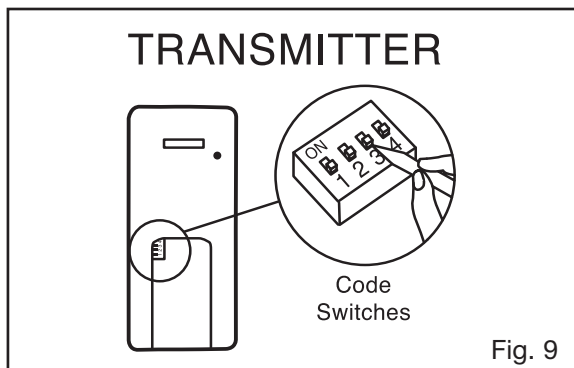

Operating buttons on the transmitter:

- HI – fan high speed
- MED – fan medium speed
- LOW – fan low speed
- FAN OFF – fan speed off
- LIGHT – light brightness and off
- FOR/REV – forward or reverse (down or up) air flow

- The light function is controlled by pressing the light button. Hold button down to increase or decrease light brightness. Tap button quickly to turn light off or on.
- Keep pressing the button for more than one second to dim the light and vary it cyclically from dim to bright and back again.
- The light button has auto return (memory function), so it will stay at the same brightness as the last time it was turned off.
- Range of the transmitter is approximately 25 ft. A new alkaline battery will typically give range of 35 ft. or more.

IMPORTANT: To prevent damage or cause injury, be sure that fan is switched to off and blades have stopped moving completely before attempting to change direction of rotation.

Forward/Reverse Direction:

Forward is a counterclockwise rotation of the blades when viewed from beneath the fan. This will create a downward breeze that can be felt below the fan. This is the normal direction for the fan to run when the weather is warm.

Reverse (clockwise) will draw air up through the blades and towards the ceiling, down the walls, and into the living space during the cooler months.

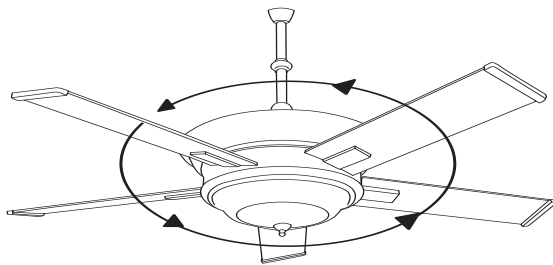

WARM MONTHS
Forward (counterclockwise)

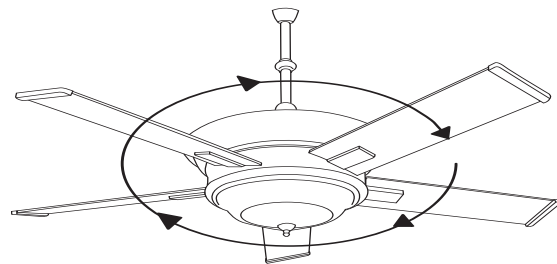

COOL MONTHS
Reverse (clockwise)

CARE AND CLEANING

Periodic cleaning of your new ceiling fan is about the only maintenance that is needed. Only use a soft brush or lint free cloth to avoid scratching the finish. **DO NOT** use water when cleaning your ceiling fan. It could damage the motor or the wood blades, and/or create the possibility of electrical shock.

NOTE: Periodically it may be necessary to re-tighten blade screws to prevent clicking or humming sound during operation. This is especially true in climates with broad temperature and humidity ranges and in fans with painted or high gloss blades.

NOTE: When dusting the blades, you must support the blade to prevent bending - no pressure should be applied to the blades.

IMPORTANT: To prevent damage or cause injury, be sure that fan is switched to off and blades have stopped moving completely before attempting to change direction of rotation.

1. If fan will not start: Check main and branch circuit breakers and/or fuses. Check line wire connections to fan and switch housing wiring. Make sure forward/reverse switch is set to one or the other position, not stuck in between.
2. If fan is noisy: Check and make sure that all screws in motor housing are snug (but not over tight). Check that the screws securing blade brackets to the motor are tight. Check that wire connectors in switch housing are not rattling against each other or the interior wall of the switch housing. Check that all glassware is finger tight and that bulb(s) are well held in the sockets, if a light kit is used. Check that the canopy is firmly attached to hanging bracket and not vibrating against ceiling.
3. If fan wobbles: Check that all blades are firmly screwed into blade arms. Check that all blade arms are firmly secured to the motor. Make sure that the light kit (if present) is firmly attached to switch housing and that all glassware and shades are fastened properly. Wobble can also result from even the smallest deviations in distance from blade tip to blade tip - if measurements from blade tip to blade tip are not equal, loosen screws connecting blade to bracket one at a time and adjust blade(s) so that distances are equal. Interchanging adjacent blades may redistribute mass and result in smoother operation. Blade arms can be bent slightly to restore same pitch to all blades if a blade is different than the other blades when viewed edge on.

THANK YOU FOR PURCHASING A REGENCY CEILING FAN.

Write to us at:

Regency Ceiling Fans
P.O. Box 730
Fenton, MO 63026

For additional troubleshooting tips,
visit us on the Web at: www.regencyfan.com